

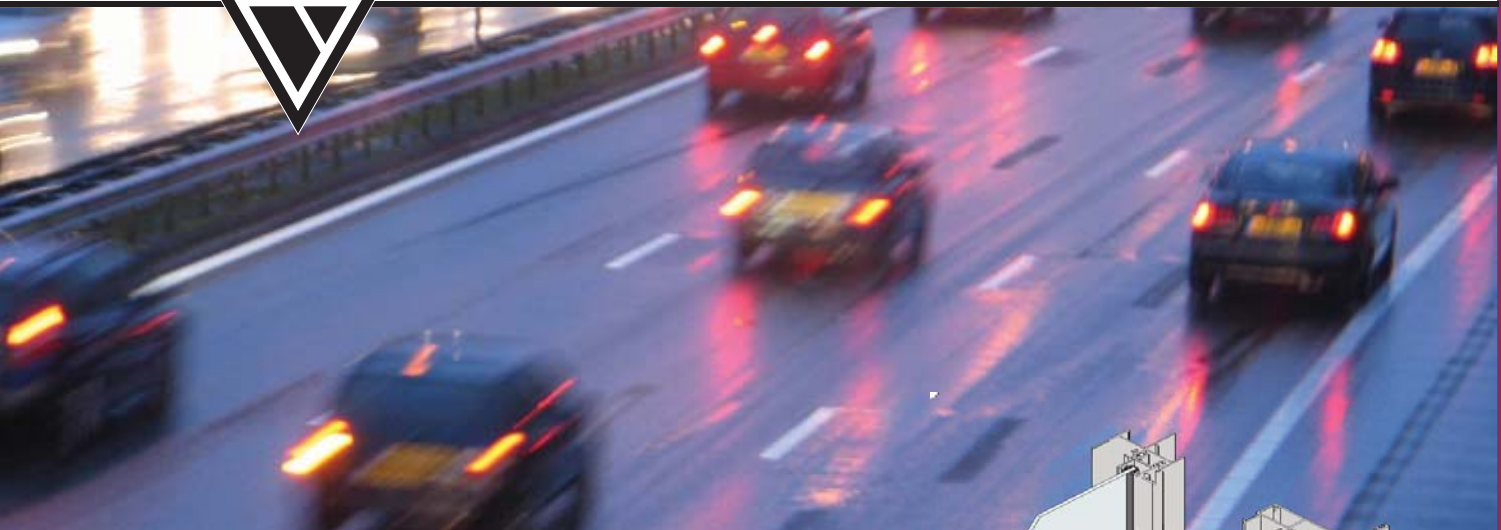

Series 531 SoundOUT™ Sliding Window



DESIGN FEATURES

- The Series 531 SoundOUT™ Sliding window has been specially designed to reduce noise infiltration through window openings. The SoundOUT™ sliding sash system is designed to be installed behind existing or new windows usually on the reveals within the wall dimension. Product has been tested at the National Acoustic Laboratories, Chatswood, N.S.W.
- Sashes are double sealed at all joints for maximum soundproofing.
- Several locks to choose from including centre multi point locking.
- All sashes on the SoundOUT™ system can be opened to allow cleaning of the inner face of the outer window.
- Sashes run on large diameter heavy duty wheels, nylon tyred ball bearing wheels used on the heavier sashes. These wheels are height adjustable to allow sashes to be squared up in the frame.
- Sashes will accept glass up to 7.52mm thick with full wrap around PVC glazing channel or if preferred SoundOUT™ sashes can be double glazed.
- Installing this product will create a thermally broken double glazed window that will significantly reduce heating and cooling costs.
- Corner and bay type windows can be fabricated in SoundOUT™ with 90° and 135° couplers that snap to the frame, no ugly rivets or screws required.

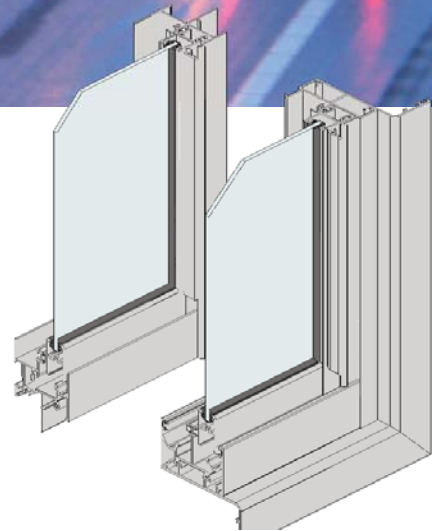

Maximum Panel Height	Various
Maximum Panel Width	Various
Maximum Glass Thickness	≤ 20mm

Subject to individual site conditions. Contact AWS Technical Support for more information.



ENHANCED ACOUSTIC PERFORMANCE



3D & 2D CAD FILES AVAILABLE



PRODUCT INFORMATION AVAILABLE AT WWW.VANTAGEALUMINIUM.COM.AU



SPECIFIER ASSISTANCE AVAILABLE

TYPICAL CONFIGURATIONS

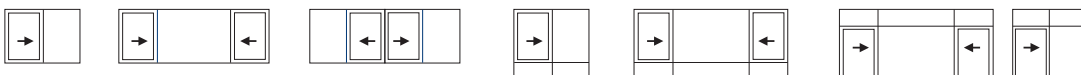



Series 531 SoundOUT™ Sliding Window

01.09

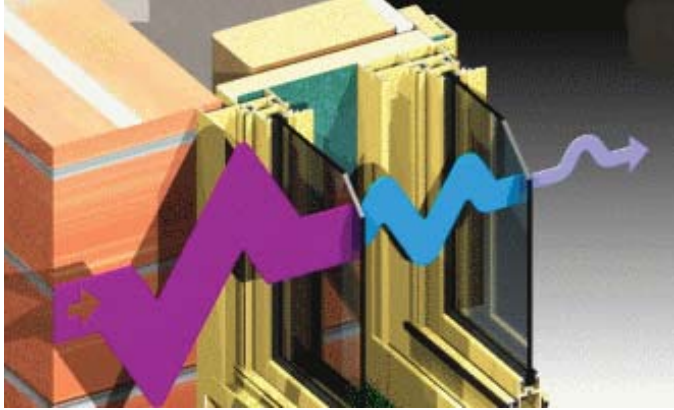

For serious sound reduction use Vantage SoundOUT™. In some cases the SoundOUT™ window may perform better than the wall it's being built into.

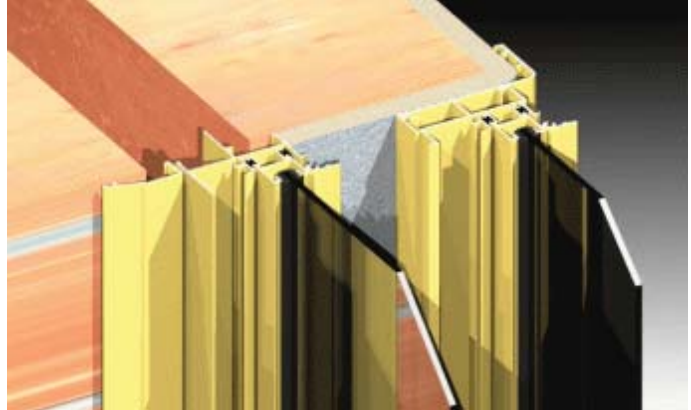

The best results are achieved by fitting the SoundOUT™ sliding windows behind a well sealed conventional window with 75mm to 100mm gap.

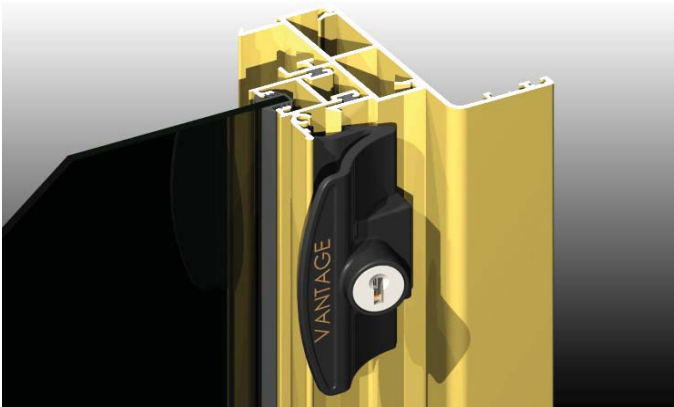

The standard latch/lock on Series 531 secures the panel behind the external opening panle to the jamb. This latch can be key locked to match other Vantage windows. We also offer these locks in a variety of colours to match the window framing.



SoundOUT™ sashes can be fitted with custom centre lock. This lock throws an aluminium rod into head keeper for maximum security.

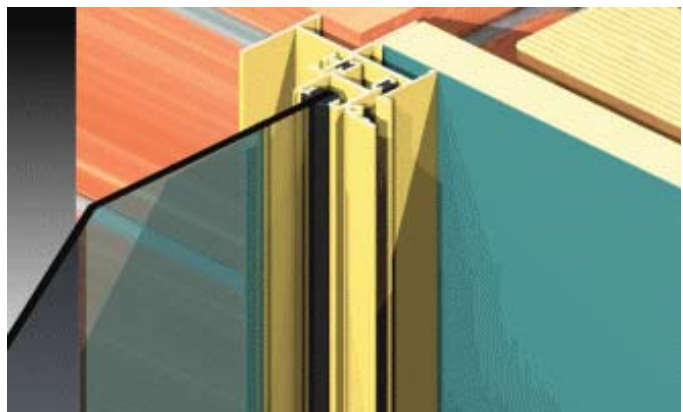

Good sound reduction numbers can also be achieved with Vantage single windows glazed with 6.38 and 7.52mm laminated glass. Awnings always give the best sound reduction numbers.



2D & 3D CAD FILES AVAILABLE

GO TO: www.vantagealuminium.com.au >

CAD & Revit 3D Files

CAD file: DWG or DXF VAN_531



MORE INFORMATION

For the latest updates regarding this product visit our website

www.vantagealuminium.com.au