



Series 516 Residential Awning Window



DESIGN FEATURES

- Successfully tested to comply with Australian Standard AS 2047.
- Optional mullion strengths cover a large variety of design wind load areas.
- Continuous hinge hood protects the top of the sash from water intrusion.
- Water resistance rating of 450Pa allows this awning window to be used in most exposed residential locations in Australia.
- Awning type sashes are fitted with heavy duty chain winders. Our manual chain winder is illustrated on the back page along with the relevant features.
- Casement type sash option available. These sashes are fitted with stainless steel friction stays and wedgeless cam handles.
- Adjoining fixed sidelights and/or lowlights have matching splayed glazing beads.
- Fixed sidelights and lowlights can be supplied with optional self draining ball valve that drains condensation water back to the outside while preventing blow backs through the drainage hole.
- Optional 20mm insulating glass available.
- Moulded nylon sash corner guards designed to protect the exposed lower corners when the awning sash is in the open position.
- Custom co-extruded Santoprene bulb seal for maximum weather performance.

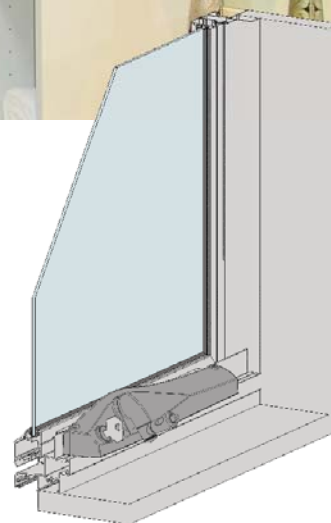

Maximum Panel Height	2060mm
Maximum Panel Width	1210mm
Maximum Glass Thickness	≤ 20mm

Subject to individual site conditions. Contact AWS Technical Support for more information.



WERS RATED PRODUCT



ENHANCED ACOUSTIC PERFORMANCE



3D & 2D CAD FILES AVAILABLE



PRODUCT INFORMATION AVAILABLE AT
WWW.VANTAGEALUMINIUM.COM.AU



SPECIFIER ASSISTANCE AVAILABLE

TYPICAL CONFIGURATIONS

Awning Style



Casement Style

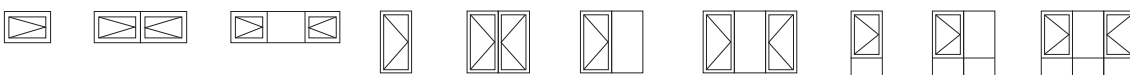



Series 516 Residential Awning Window

01.09

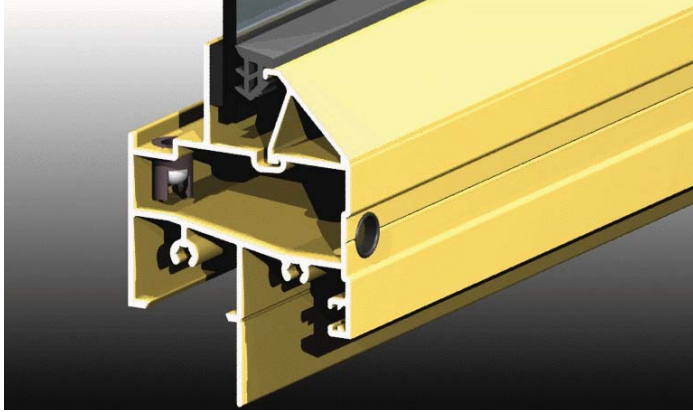

If you live in a cold climate we offer an optional fixed sump sill with anti blow back ball valve to take care of condensation.

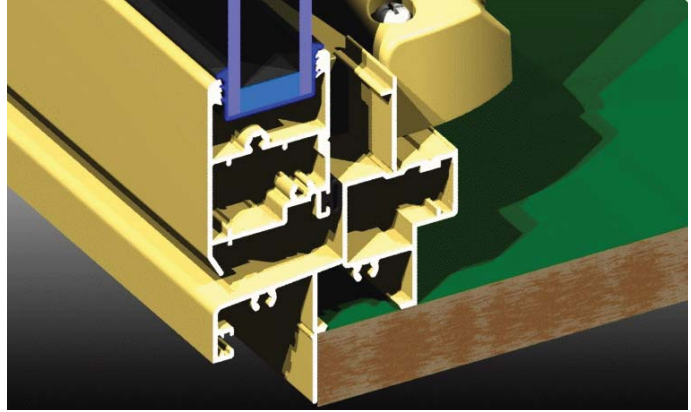

We have several sashes to choose from the picture above shows our custom double glazed wrap around sash. This sash will accept 20mm Insulating Glass Units.



The standard chain winder used on Series 516 comes standard with stainless steel chain and Polesium™ cover and base. These corrosion resisting features make the winder suitable for exposed locations. 10 Year manufacturers warranty. We also fix the winder to the frame and sash through thickened area.



The lower corners on awning sashes are protected with nylon wrap around guards. This reduces the chance of injury if someone walked into an open sash.

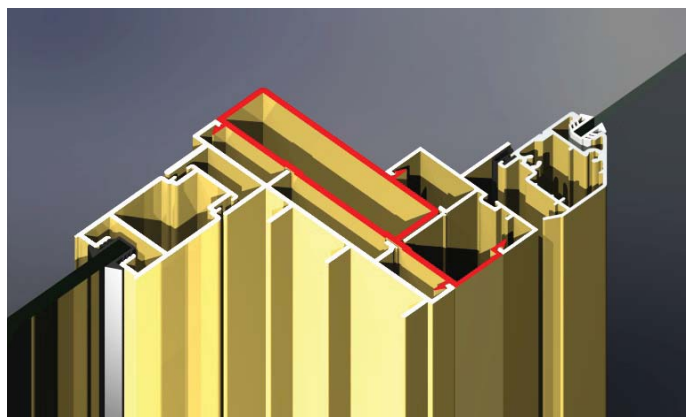

We offer an extensive range of snap fit couplers for all Vantage windows and doors. The picture above shows an awning window clipped to a sliding door.



2D & 3D CAD FILES AVAILABLE

www.vantagealuminium.com.au >

CAD & Revit 3D Files

CAD file: DWG or DXF VAN_516



MORE INFORMATION

For the latest updates regarding this product visit our web site

www.vantagealuminium.com.au

