



Architectural Information

Glazing - Residential Guide

AS1288 Impact on Residential Windows & Doors

Page: **03.1**

Date: Mar 07

Replaces: May 06

Scale: Not to scale



AS 1288-2006 Residential Guide for Windows

refer AS1288-2006 for more information

These information pages have been produced in good faith and believed by Architectural Window Systems Pty Ltd to be correct and appropriate, it is given without liability or responsibility on the part of Architectural Window Systems Pty Ltd. The correct usage of glass is critical in window and door fabrication and we recommend that you purchase and carefully read AS1288-2006.

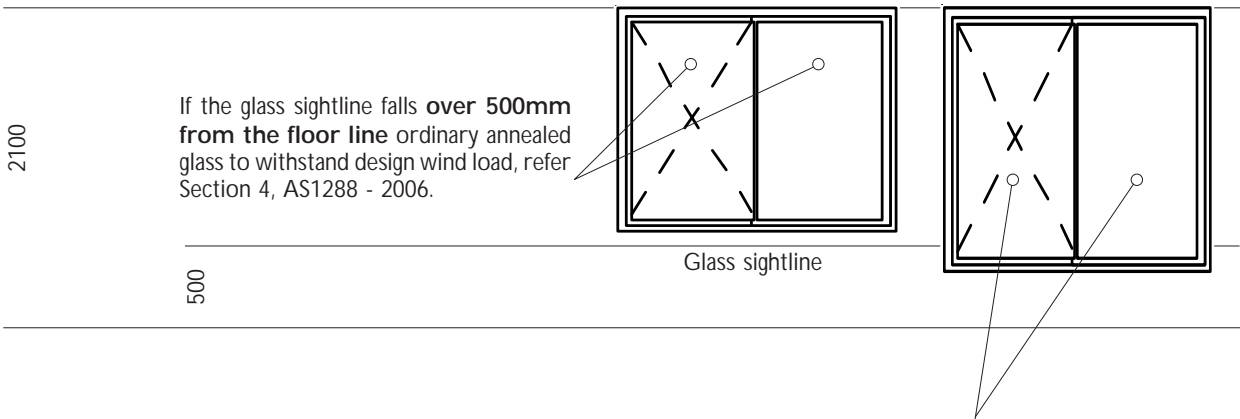

If the glass sightline falls **within 500mm of the floor** then Section 5, AS1288-2006 applies and Grade 'A' safety glass must be used.

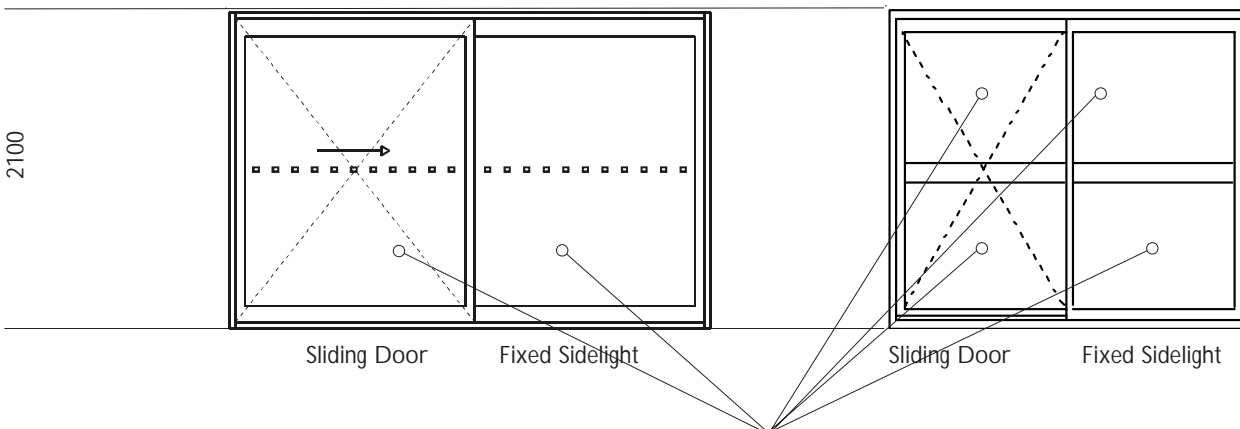

Glass in all doors and adjoining sidelight/s to be Grade 'A' safety glass.

AS1288-2006, Clause 5-19, Making glass visible (Manifestation)

If the presence of glass in a door, side panel or panel capable of being mistaken for a doorway or opening is not apparent by transoms, colonial bars, other components of the glazing system, or other decorative treatment, such as being opaque, or patterned, the glass shall be marked to make it visible. Refer AS1288-2006 for details on glass marking and location of this marking.

AS 1288-2006 Residential Guide for Windows

refer AS1288-2006 for more information

These information pages have been produced in good faith and believed by Architectural Window Systems Pty Ltd to be correct and appropriate, it is given without liability or responsibility on the part of Architectural Window Systems Pty Ltd. The correct usage of glass is critical in window and door fabrication and we recommend that you purchase and carefully read AS1288-2006.

On this window next to the fixed door panel can use ordinary annealed glass in accordance with design wind load.

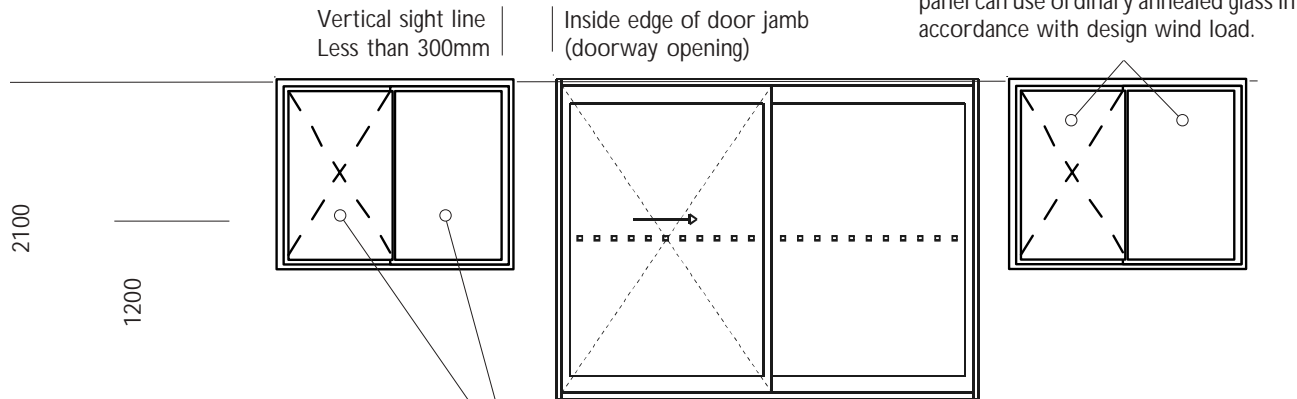

Glass within 300mm of door opening and less than 1200mm from floor level to be Grade 'A' safety glass

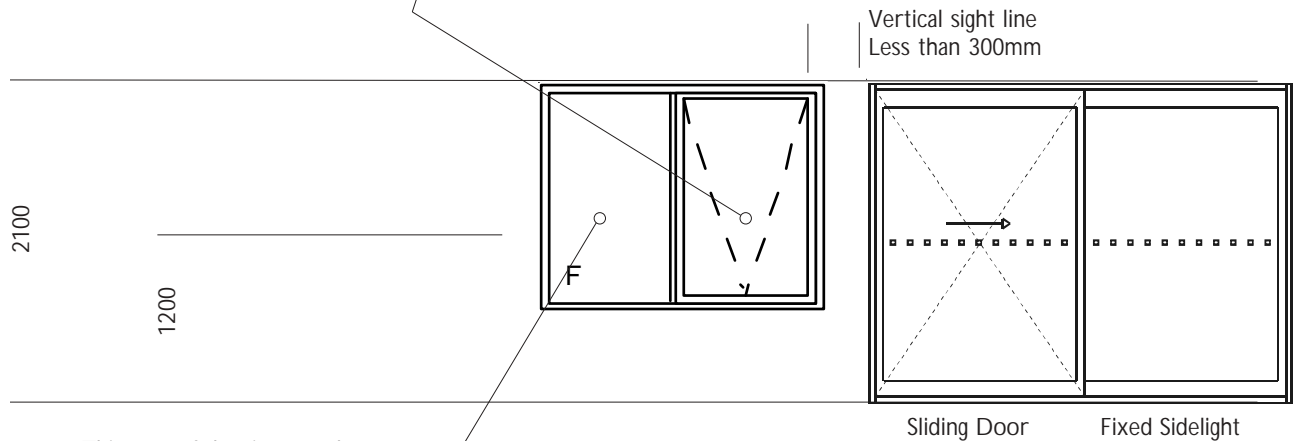

This pane of glass is more than 300mm away from the door opening and can't be moved any closer therefore ordinary annealed glass is suitable refer Section 4, AS1288-2006.



AS 1288-2006 Residential Guide for Bathroom Windows

refer AS1288-2006 for more information

These information pages have been produced in good faith and believed by Architectural Window Systems Pty Ltd to be correct and appropriate, it is given without liability or responsibility on the part of Architectural Window Systems Pty Ltd. The correct usage of glass is critical in window and door fabrication and we recommend that you purchase and carefully read AS1288-2006.

These windows require Grade 'A' safety glass

Any window glass within 2000mm of the floor line to be Grade 'A' safety glass

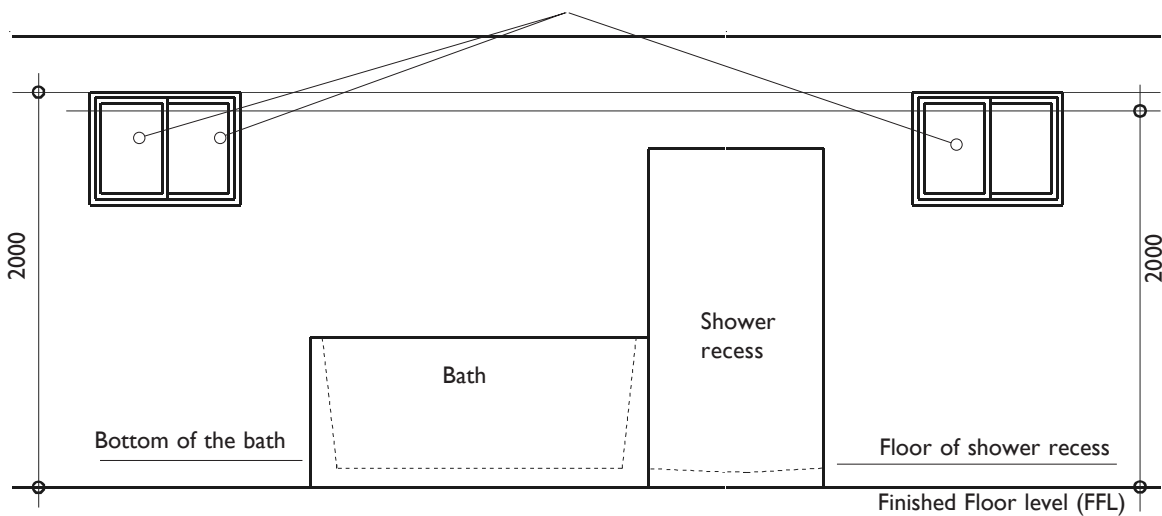

All glazing within 2000mm of the finished floor level (FFL) in a wet area must be Grade 'A' safety glass, in accordance with Section 5, AS1288-2006.

