

AVERSATILE RANGE

A comprehensive suite of Designer Series THERMAL HEART™ products is offered – awning, casement, and bi-fold windows, hinged and bi-fold doors. Designer Series THERMAL HEART™ not only offers excellent suitability for thermal performance but is capable of impressive product sizes allowing the large heights and spans sought by many designers and homeowners to be achieved (doors are suitable to heights of 2.4m).

WIDE APPLICABILITY

Windows and doors are based on a large 44mm glazing platform making them suitable for a wide range of residential and architectural glass applications. While the standard double glazed unit offered is 24mm thick.

DOUBLE GLAZING SYNERGY

When combined with double-glazing, our Designer Series THERMAL HEART™ windows and doors meet contemporary aspirations for energy conservation and comfortable interior temperatures. In terms of thermal efficiency, this new product range rates 32% better than standard double glazed windows and doors.



Hinged door frame

DUAL COLOUR OPTION

The unique thermal insulator jointing method allows a different choice of colour to compliment both internal and external colour palettes resulting in one colour on the outside and another on the inside.

Designer Series THERMAL HEART™ profiles feature a glass fibre-reinforced nylon thermal break for enhanced insulation of the aluminium. These are indicated by the red circles.



World-leading technology is being used by AWS to ensure that its new Designer Series THERMAL HEART™ range of windows and doors has the strength to perform in the toughest environments.

A state of the art thermal break machine from the Aluro company, in Belgium, inserts the polyamide nylon strip and rolls the three components - aluminium interior, exterior and thermal strip - tightly together in one rigid profile.

The Aluroller, as the 11-metre-long machine is called, was chosen ahead of alternative technologies, because the combining process retains the components in their straight orientation rather than rolling them together through a rolling head with the possibility of unwanted profile bending.

Your local Designer Series THERMAL HEART™ manufacturer



DESIGNER SERIES WITH
THERMAL HEART™



76-78 JEDDA ROAD, NSW 2170, AUSTRALIA
P +61 2 8783 7611 F +61 2 8783 7633
W www.vantagealuminium.com.au



MAXIMISE ENERGY EFFICIENCY & COMFORT
THERMALLY BROKEN ALUMINIUM WINDOWS AND DOORS

THERMAL HEART™ is the technology that lies at the heart of a new thermally efficient range of aluminium windows and doors.

Released as part of the Designer Series, this innovative new product range is ideal for those jobs where minimising cold and heat transfer is a priority. Its release coincides with new Government requirements on energy efficiency in homes.

The new range is 32% more thermally efficient than standard double glazed windows and doors.

THERMAL BREAK TECHNOLOGY

THERMAL HEART™ products include a glass fibre-reinforced nylon insulator or thermal break between the aluminium exterior and interior elements.

ARCHITECTS' CONVENIENCE

The extra insulation provided by THERMAL HEART™ technology allows designers additional flexibility when achieving Building Code compliance with houses that incorporate large areas of glazing.

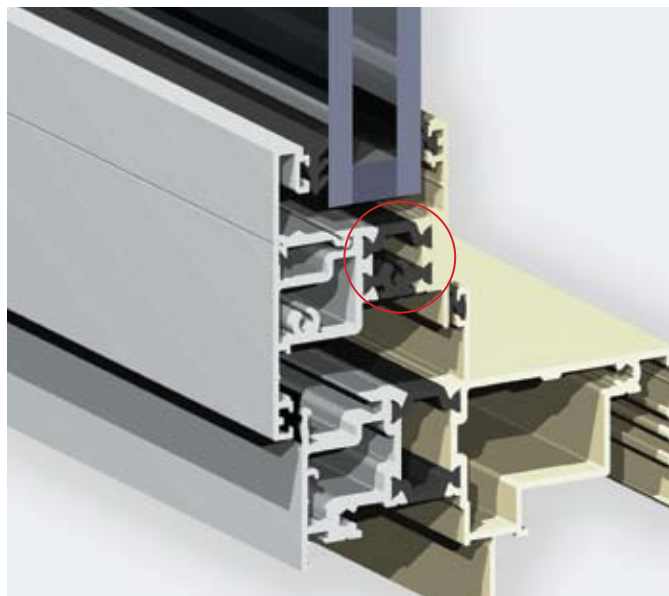

Awning window frame



WINDOW FRAME & SASH

This window frame and sash demonstrates the dual colour capability of the Designer Series THERMAL HEART™ range. The frame and sash set the theme for a flat faced, square edged aesthetic common to all Designer Series products. Window mullions have internal stiffening boxes rather than external fins to also improve aesthetics.



The polyamide thermal break incorporated into profiles will generally show up as black. These breaks are only seen when windows or doors are in an open position and even then they are relatively unobtrusive.



HINGED DOOR FRAME & PANEL

The Designer Series THERMAL HEART™ range has been designed with flat faces for a clean, contemporary look. In this respect it mirrors the design approach adopted for standard Designer Series products. Corners have generally been squared off, with externally applied glazing beads also following a square, rather than sloped, shape.



Double glazing will be used as standard with Designer Series THERMAL HEART™ products to obtain maximum thermal benefit from the insulated window system. Glass panel thickness of up to 32mm is possible. Typically standard double glazed panels are 24mm thick.



BI-FOLD DOOR

The Designer Series THERMAL HEART™ bi-fold doors and windows incorporate a reliable bottom mounted roller system for smooth, reliable, performance. Our heavy duty quad rollers run on a matching double track for optimum performance and support this ensures heavy panels operate easily.

WERS RATINGS

WERS is the official energy rating scheme for windows in Australia. All Designer Series THERMAL HEART™ products have been WERS rated. For more information on the performance of THERMAL HEART™ products visit the Vantage website www.vantagealuminium.com.au

